

(No Model.)

4 Sheets—Sheet 1.

D. L. PETITPIERRE.

WATCH MAKER'S LATHE.

No. 258,669.

Patented May 30, 1882.

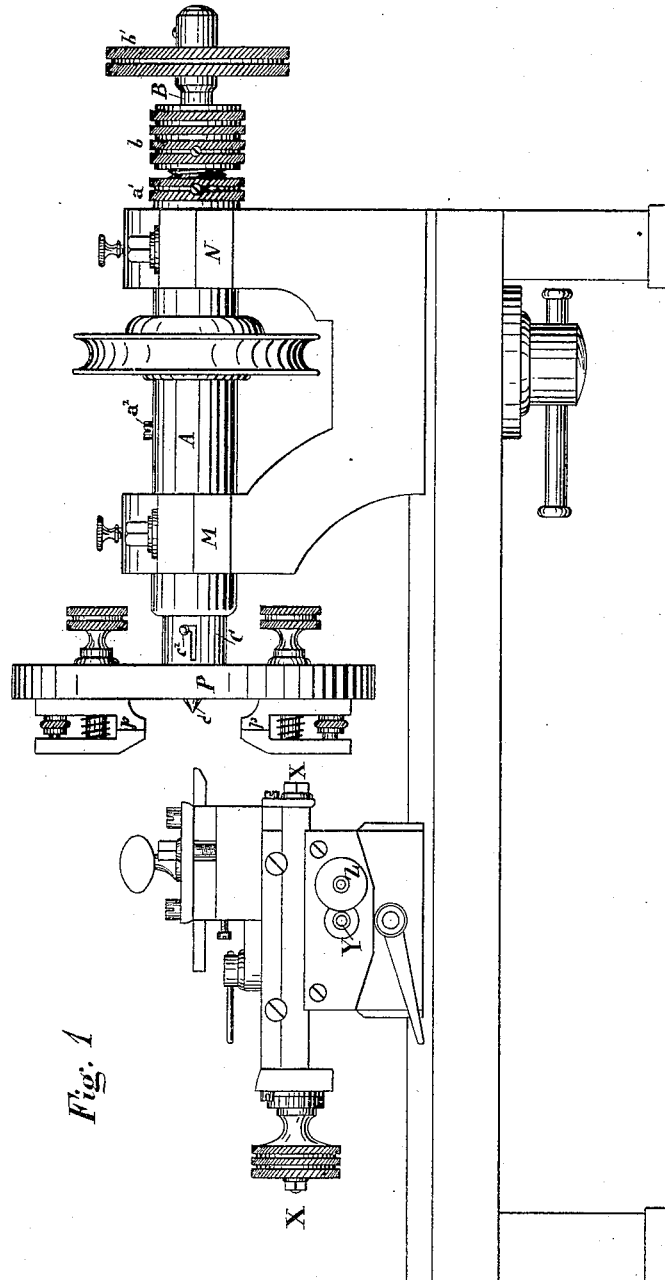

Fig. 1

Witnesses

Chas. H. Smith
Harold Terrell

Inventor

D. L. Petitpierre

per Lemuel W. Terrell
att'y

(No Model.)

4 Sheets—Sheet 2.

D. L. PETITPIERRE.

WATCH MAKER'S LATHE.

No. 258,669.

Patented May 30, 1882.

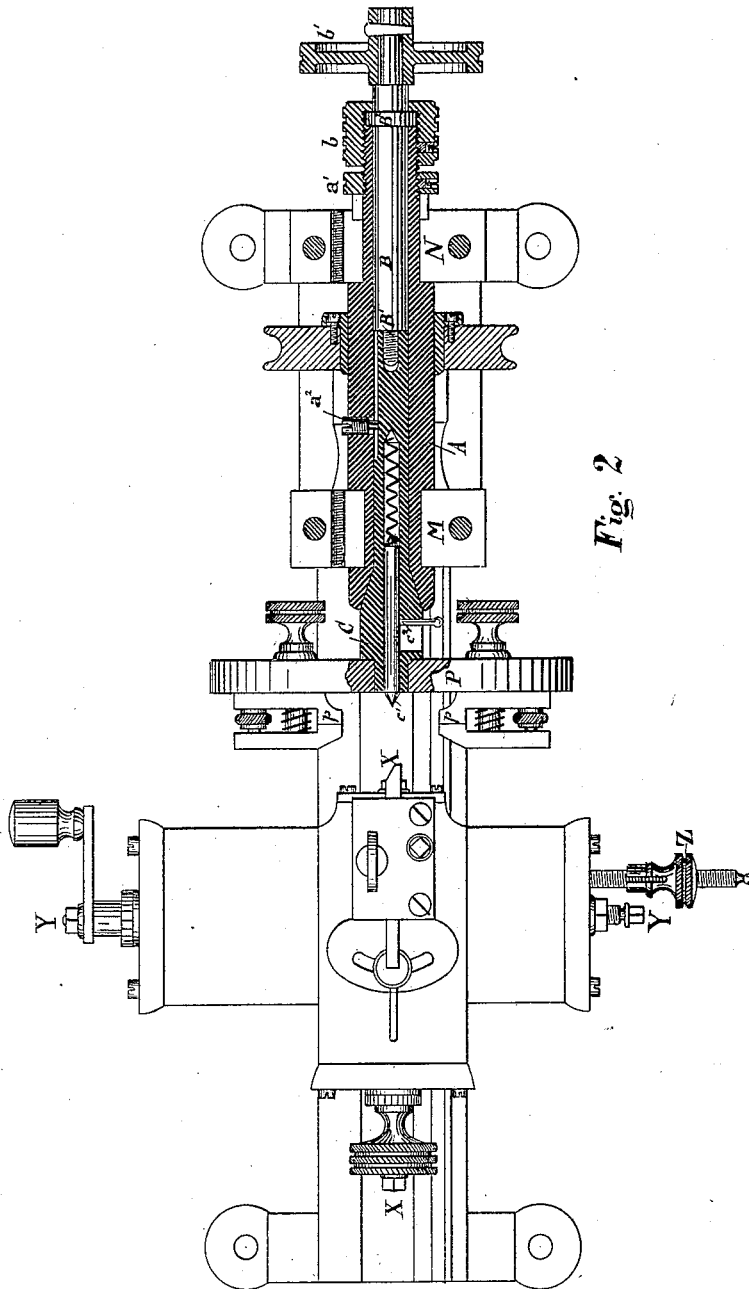

Fig. 2

Witnesses

Chas. H. Smith
Harold Terrell

Inventor

D. L. Petitpierre
Harold W. Terrell

(No Model.)

4 Sheets—Sheet 3.

D. L. PETITPIERRE.

WATCH MAKER'S LATHE.

No. 258,669.

Patented May 30, 1882.

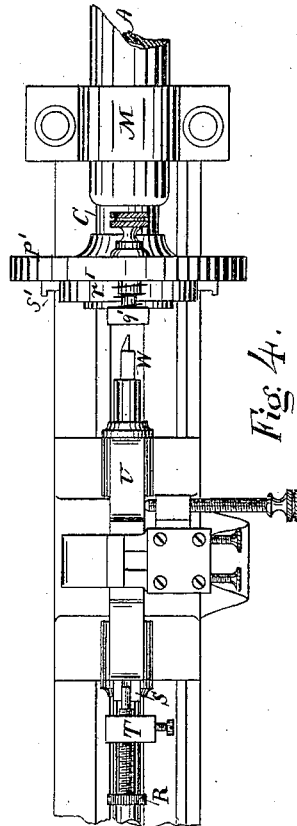
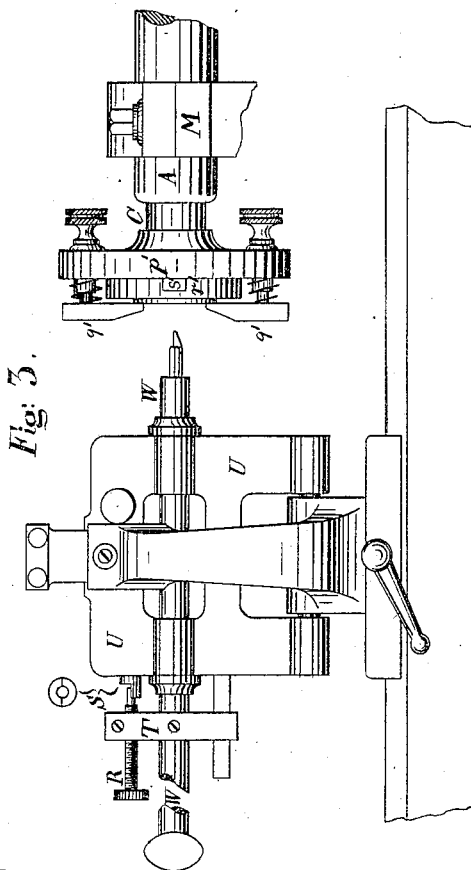
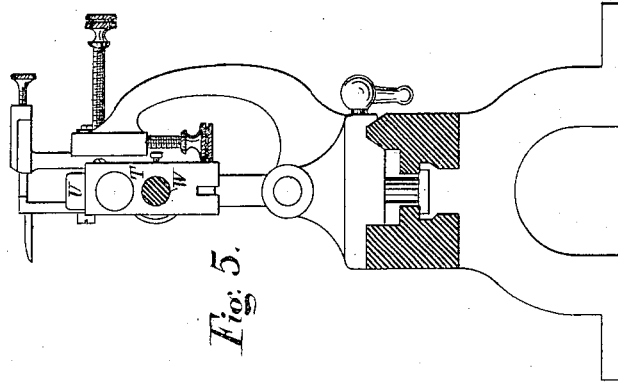

Witnesses

*Chas. H. Smith,
Harold Terrell*

Inventor

*D. L. Petitpierre
per Samuel W. Serrell
att'y*

(No Model.)

4 Sheets—Sheet 4.

D. L. PETITPIERRE.

WATCH MAKER'S LATHE.

No. 258,669.

Patented May 30, 1882.

Fig. 8.

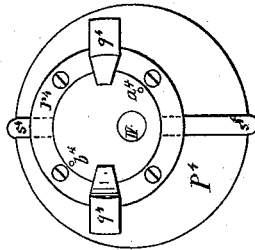
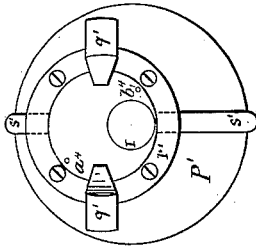

Fig. 11.

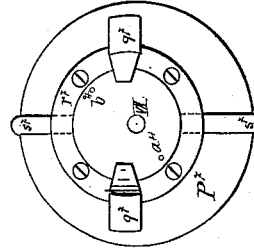

Fig. 14.

Fig. 7.

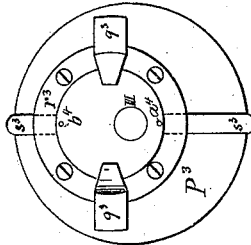
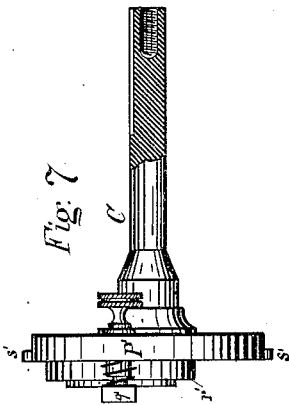

Fig. 10.

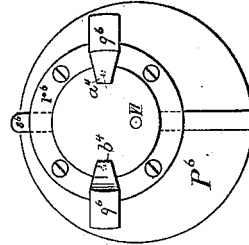

Fig. 15.

Fig. 6.

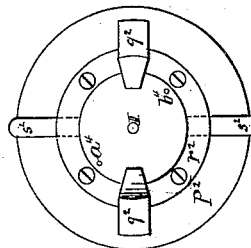
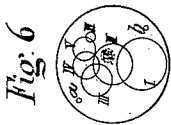

Fig. 9.

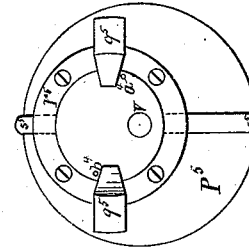

Fig. 12.

Witness

Chas. H. Smith
Harold Serrell

Inventor

D. L. Petitpierre
per Lemuel W. Serrell

UNITED STATES PATENT OFFICE.

DAVID L. PETITPIERRE, OF COUVET, NEUFCHATEL, SWITZERLAND.

WATCH-MAKER'S LATHE.

SPECIFICATION forming part of Letters Patent No. 258,669, dated May 30, 1882.

Application filed January 25, 1882. (No model.) Patented in France December 13, 1881.

To all whom it may concern:

Be it known that I, DAVID LOUIS PETITPIERRE, a citizen of Switzerland, residing at Couvet, in the Canton of Neufchatel, have invented a new and useful Improvement in Tools for Watch-Makers, (for which I have claimed a patent in France, bearing date December, 1881,) of which the following is a specification.

The said improvement in tools for watch-makers consists in a special construction of the watch-maker's lathe, the so-called "burin fixe," or universal lathe, the purpose of which is to enable completely to finish with a perfect exactness, and at the same time in the speediest manner, the pillar-plates of watches for a given caliber without the necessity of marking the said caliber on the pillar-plate before placing it on the lathe.

In the annexed drawings, Figure 1 shows a raised plan of my improved burin fixe. Fig. 2 is a plan, in which a horizontal section shows the particular disposition of the axis as I have contrived it for the purpose hereinafter set forth. Figs. 3, 4, and 5 represent an elevation view, a plan view, and a back view of the apparatus contrived to perform on the same lathe the boring for the stones, which apparatus has likewise been also improved by me. Lastly, Figs. 7 to 14 show the spare plates (plateaux de rechange) which make up the chief part of my invention.

The hollow axis A of the lathe, Fig. 2, revolves in the bearings M and N, in which it is fastened, as in the usual lathes, by the screw-nut a' . The pin B has its tapped end engaged in the hollow axis A, in which it turns freely. The collet B², turning in the socket b , prevents the pin B from getting out of the axis A. Lastly, the disk b' , wedged upon the end of the pin, enables the latter freely to turn.

The universal plate P, with the pinchers, so-called "chiens," p p , is, as far as the other parts are concerned, exactly the same as those of the common lathes, and it is fixed upon a pin, C, provided with a conical pitch, which exactly fits the hollow axis A. The cylindrical part of the pin C is provided with a longitudinal groove, into which the end of the small screw a^2 penetrates. On the other hand, this pin C is fitted with a tapped hole corresponding with the screw B', so that when the latter is screwed to the pin C the plate P is firmly

and exactly secured to the axis A of the lathe. Lastly, inside the pin C is adapted a small centering-pin, c' , (broche de centrage,) exactly like that of the common lathes, so-called "burins fixes."

The construction of the axis of the lathe as I have just described it is intended to permit quickly to replace the plate P, which is used to do all the accessory works, by any of the spare plates represented in the Figs. 7 to 14, and to fix the latter firmly to and quite in the center of the axis A. All these plates bear a pin exactly fitting the axis A, and provided with a cylindrical part and a conical pitch. They are, moreover, all provided with a groove, into which the screw a^2 penetrates, and with a tapped hole corresponding with the screw B. On the other hand, the universal plate P is alone provided with the centering-pin c' , (broche de centrage.)

Caps such as r' r^2 , &c., the inside diameter of which is exactly equal to the size of the pillar-plate in question, are screwed upon the plates P' P² P³, &c., the depth of their sinking being a little less than the thickness of the said pillar-plate. The caps r , which are all alike, bear moreover two little pins, a^4 and b^4 , placed on the same diameter and at quite the same distance from the center, which are intended to determine the position that the pillar-plate is to assume within the caps, and which fix the point of the caliber of each mover. Besides this, each plate is provided with two pinchers, so-called "chiens," $q' q' q^2 q^2$, &c., the use of which is to fasten firmly the pillar-plate in the caps $r' r^2$, &c. Lastly, the push-pieces $s' s' s^2 s^2$, &c., are disposed in such a manner as to enable easily to remove the pillar-plate out of the cap, when the work is finished. These push-pieces $s s' s^2$, &c., are fitted to slide in grooves in the plates P' P² P³, &c., and are made with beveled inner ends, to pass in beneath the back of the pillar-plate and force said pillar-plate away from the bottom of the cap. Each of the caps, $r' r^2$, &c., is placed on the plate P' P², &c., in such a manner that the center of the plate—viz., the geometrical axis of the lathe—exactly corresponds with one of the points of the caliber—namely, with the center of one of the movers. These preliminaries granted, it is easy to understand how, by making use, moreover, of two bench-marks, a^4 and b^4 , the position of which is

once for all fixed in the caliber traced out, it will be sufficient to place a pillar-plate already turned as to the size and thickness, and provided besides with two holes situated on any diameter, but bored at a distance from the center exactly determined, into the cap of the plate which may happen to be placed then on the lathe, to make, without any grouping, at the required place the sinking necessary for the mover corresponding with the position of the cap upon the plate, as well as for the setting of the stone, &c. Thus, for instance, the caliber being given which is represented in Fig. 6, the movers of which are, the barrel, I; the central wheel, II; the third wheel, III; the fourth wheel, IV; the cylinder-wheel, V; the balance, VI, and the minute-wheel, VII, I dispose upon the seven plates represented in Figs. 7 to 14 the caps r' , r^2 , &c., in such a manner that by placing on the plate P' a pillar-plate turned as to the size and thickness, and provided with the holes corresponding with the pins a^4 and b^4 , the center of this plate—viz., the axis of rotation of the lathe—may correspond with the center of the barrel. For the plate P^2 the cap r^2 is placed at the center of the plate, since it corresponds with the central wheel. The cap r^3 is placed on the plate P^3 so that the center of the latter corresponds with the axis of the third wheel, when the plate provided with the sinking of the barrel is fixed to the pins a^4 and b^4 , and so on.

The plates P' , P^2 , &c., corresponding with a given caliber, being once prepared, it is easy to conceive how the workman must proceed quickly to finish a great number of pillar-plates. The pillar-plates are prepared by the usual mechanical process as to their size and thickness. Moreover, two holes exactly corresponding with all the pins a^4 and b^4 of the caps must previously be bored into them. If, then, you fix upon the lathe the plate P' , the workman must begin thoroughly to prepare the place for the barrel on all the plates. Replacing then the plate P' by P^2 , he must do the same for the central wheel, and so on until the pillar-plate is ready to be gilded or nicked.

When making the sinkings, the workman must of course make use of the usual millimetric divisions which are given on the adjusting-screw X and Y of the two slides X' and Y', and likewise of the stop-knob Z, which is to be placed once for all for each plate—viz., for every mover.

It is almost useless to add that when the caliber for which the plates P' , P^2 , &c., are disposed should have come out of fashion, or should for any reason whatever no longer be required, the same plates may easily be transformed so as to be available for another caliber. The caps r' , r^2 , &c., may also be made useful again if the diameter of the pillar-plate be not smaller than that of the former.

To prepare the sinking for the stone, the workman must use the usual tool represented in the Figs. 3, 4, and 5, by means of which he can make the sinking with exactly the same diameter as that of the stone.

In order to enable the workmen to give to the sinking exactly the required depth, I have contrived the following disposition of the parts which are represented in the Figs. 3, 4, and 5: In the support T, fixed to the pin bearing the graver W of the tool in question, I place a screw, R, which enables to limit the run of the graver in the longitudinal direction. I likewise fix to the strap U a little shoe, S, into which the end of the screw engages itself. Let us now suppose that the graver be placed exactly on a level with the pillar-plate at the place where the sinking is to be made into which a ruby must be placed. I stick with a little saliva the ruby against the bottom of the little shoe S. I then turn the screw R until it touches the surface of the stone. If I now take off the latter with pinchers, there will remain between the end of the screw R and the bottom of the shoe S a space exactly equal to the thickness of the ruby. Consequently I need only sink the graver until the screw R reaches the shoe S, and the sinking will have exactly the required depth.

Having thus described in a simple and clear manner the chief features of my invention, what I claim is—

1. In a watch-maker's lathe, the tubular shaft A, plate P, and pin C, in combination with the pin B, disk B², and nuts a' b, substantially as and for the purposes specified.

2. The plate P' , in combination with the cap r' , secured thereto, the pins a^4 b^4 in the cap, and the dogs q' upon the plate P' , substantially as and for the purposes specified.

3. The plate P' , in combination with the cap r' , pins a^4 b^4 , dogs q' , and push-pieces s' , substantially as and for the purposes specified.

4. The strap U, support T, spindle W, and boring or sinking tool, in combination with the screw R passing through such support, and the shoe S upon the strap U, substantially as and for the purposes specified.

5. In the manufacture of pillar-plates for watches, the several plates P' , P^2 , P^3 , &c., adapted to hold the pillar-plate during the several operations, each provided with a cap to receive the pillar-plate, pins to position the pillar-plate, and dogs to hold it within the cap, the caps and pins so placed that the pillar-plate is brought to its proper position successively upon the respective plates to bring the center to be bored central with the axis of the plate to which it is held, as specified.

DAVID LOUIS PETITPIERRE.

Witnesses:

THÉODORE FRUER,
ELMER SCHNEIDER.